

Postforming Grade Laminate (HGP)

The postformable laminate that unleashes your design ideas away from the straight edge

GENERAL DESCRIPTION

FORMICA® Decorative Laminate is a postforming grade high pressure decorative laminate.

Internal or external curves can be formed down to a standard recommended minimum radius of 12.5mm to the back of sheet.

Benchtops, breakfast bars, special shapes and other products can be manufactured by independent fabricators to individual specifications.

USES

Formica® Decorative Laminate can be used in a variety of applications. These include; counter, bench and table tops, store fixtures, office furniture, vanity units, display work, reception areas, wall panelling, toilet partitions, and door and drawer fronts.

It is also suitable for medical, dental and food preparation areas.

PRODUCT CHARACTERISTICS

Sheet Sizes:	3600mm x 900mm (nominal)	3600mm x 1500mm
Thickness:	0.8mm	
Mass:	1.1 to 1.4 kg/m ²	
Finish:	Velvet and Pearl (limited colours in gloss)	

Tolerances comply with New Zealand Standard AS/NZS 2924.1, 1998.

SUBSTRATES

Formica® laminates should be bonded to a suitable substrate such as high moisture-resistant and standard particleboard, high moisture-resistant and marine grade ply or medium density fibreboard. A smooth surface is important. Rougher substrates such as large-chip particleboard may result in a visually unacceptable product.

LIMITATIONS

It is not recommended that full sheets of Formica® laminate be applied directly to plastered or concrete walls.

Do not use externally or in areas where prolonged exposure to temperatures exceeding 135°C may occur.

The sizes of finished components are restricted only by the laminate sheet sizes available.

PROPERTIES

Random samples of Formica® laminate are withdrawn from production runs and tested to ensure compliance with New Zealand Standard AS/NZS 2924.1, 1998.

Composition Formica® Decorative Laminate consists of several base layers of phenolic resin-impregnated kraft paper. A layer of melamine-impregnated paper in a solid colour or printed design is applied to each side of the base and covered with a translucent overlay containing melamine. The layers are bonded under heat and pressure.

The back of the laminate is sanded to permit good bonding.

Fire Indices Typical values for Formica® laminates when tested to AS 1530.3, 1989

			
0.8mm F/F	14	8	5

Tests on 0.8mm Formica® laminate were conducted by the CSIRO's Division of Building, Construction & Energy at North Ryde. The laminate was bonded with resorcinol adhesive to a 6mm fibre-reinforced cement board.

Specification New Zealand Standard AS/NZS 2924.1, 1998, Type HGP; High Pressure Decorative Laminates—Sheets made from Thermosetting Resins¹.

Finish Average gloss level using a Gardner 60° meter of 15 for velvet finish; and 92 for glossy finish.

Thickness Tolerance A variation of no more than ± 0.10mm for 0.8mm laminates.

Appearance No defects visible from a viewing distance of 1.5 metres (AS/NZS 2924.1, 1998).

Resistance to Surface Wear Wear resistance of not less than 350 taber cycles.

Resistance to Immersion In Boiling Water No more than 18% increase in weight and 20% increase in thickness for 0.8mm laminates.

No more than 15.5% increase in weight and 18% increase

Postforming Grade Laminate (HGP)

The postformable laminate that unleashes your design ideas away from the straight edge

in thickness for 1.0mm laminates.

No more than a moderate change in gloss or colour.

Resistance to Dry Heat No more than a slight change in gloss or colour after 20 minutes in contact with a container holding glycerol tristearate at 180°C for velvet finish, or a moderate change for glossy finish.

Dimensional Stability After exposure to controlled high and low humidity conditions, a dimensional change of no more than: 0.65% with the grain and 1.15% across the grain for 0.8mm laminates.

No more than 0.6% with the grain and 1.05% across the grain for 1.0mm laminates.

Resistance To Impact No evidence of cracking after dropping a ball from a specific height (height may be agreed between interested parties — AS/NZS 2924.1, 1998).

Resistance To Staining No staining by 18 specified reagents. Moderate staining by 7 additional specified reagents is permitted, but a mild abrasive creme cleanser (not recommended on glossy finish) should easily remove the stains (AS/NZS 2924.1, 1998).

Resistance To Colour Change In Artificial Light No more than a slight colour change after 48 hours exposure to carbon-arc fading lamp (minimum 4 on the grey scale (AS/NZS 2924.1, 1998).

Formica® laminates comply with the colour fastness requirements of the New Zealand Standard. They have good colour retention under normal conditions of internal use. Prolonged exposure to sunlight may cause some change in colour. For this reason, Formica® laminates are not recommended for external use.

Resistance To Cigarette Burns No more than a moderate change in gloss and moderate brown staining.

Formability Will satisfactorily postform to a minimum internal or external radius of 15mm without cracking, blistering or delaminating.

Resistance To Blistering After the sample temperature has reached 163°C, a minimum time of 15 seconds should elapse before blistering occurs.

DESIGN AND SPECIFICATION NOTES

Formica® laminate can be formed by specialist fabricators to a recommended minimum internal or external radius of 12.5mm. Some fabricators have the ability to form to radii

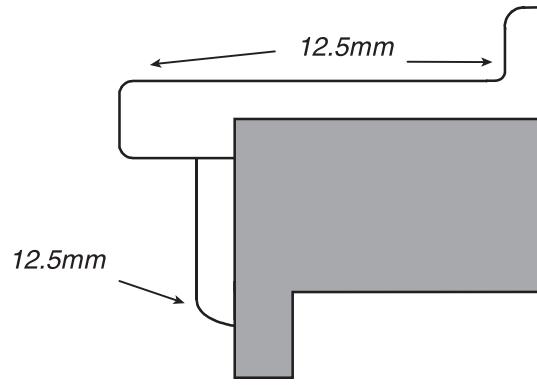

below the recommended minimum. Any requirements for smaller radii will be negotiated between specifier and manufacturer.

STATIONARY FORMING

Postforming (P/F) Laminate bonded with contact adhesive to pre-shaped core.

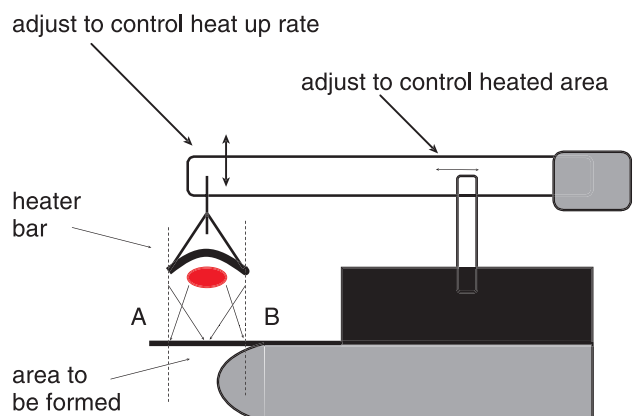
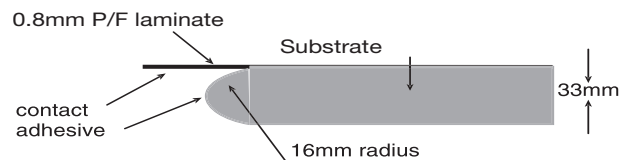

Area between A & B must reach 163°C before forming.

This temperature can be controlled and monitored by the use of "tempilaq" (heat sensitive liquid).

Apply tempilaq on the area [A & B] to be heated. Allow heat up time (see below) to elapse. The tempilaq will melt at the prescribed temperatures and give an immediate, accurate, visible indication of the temperature on the laminate surface.

1 Alternate conformance to AS/NZS 2924.1, 1998 where stated.

Postforming Grade Laminate (HGP)

The postformable laminate that unleashes your design ideas away from the straight edge

- Tempilaq must melt across area A-B to ensure tight forming.
- Ideal heat up rate is 45 to 55 sec. before forming.
- Ideal blister time is 70 to 80 sec.

Ensure the tempilaq melts across the entire area from A to B.

Any cracking along the top or bottom of the postformed edge is a clear indication of insufficient heat either on top (area B) or along the bottom (area A).

Tempilaq will indicate the area affected by insufficient heat. Adjust the heat accordingly.

Common Problems Encountered During Postforming

1. Factors affecting changes in heat up time;
 - a. Pattern
 - b. Colour
 - c. Sheet thickness
 - d. Room temperature
 - e. Board temperature
 - f. Relative humidity
 - g. Draughts from doorways or other openings
2. Main factors contributing to cracks when postforming are:
 - a. Rough cores
 - b. Wrong heat up rate
 - c. Insufficient heat
 - d. Very cold cores
 - e. Uneven heat distribution
 - f. Element too far from laminate
 - g. Heating element too cold
3. Main factors contributing to blistering when postforming are:
 - a. Heating the laminate for too long
 - b. Uneven heat distribution
 - c. Warped material
 - d. Heating element too hot
4. Main factors contributing to delamination when postforming are:
 - a. Insufficient heat
 - b. Insufficient glue
 - c. Insufficient pressure

Remember

- Temperature must be uniform along the postformed length.
- Too much tension can cause "tension cracks" as the

- laminate cools.
- Insufficient heat and pressure will leave a gap between laminate and substrate, creating a hollow area which is susceptible to cracking on impact.
- Use a hand roller to press down along bend to ensure proper adhesion to substrate.

Cooktops When using Formica® laminate as a splashback, please refer to the manufacturer's installation recommendations for cooktops around combustible materials.

WHEN SPECIFYING

Surfacing shall be Formica® Postforming Grade..... laminate as manufactured by The Laminex Group.

Colours and/or patterns shall be in..... finish.

Sheet size shall be

DESIGN CAPABILITIES

Formica® Decorative Laminate can have a 180° rounded edge. It has a heat resistant surface up to 145°C.

Contact The Laminex Group for names and addresses of Formica® postforming fabricators.

PRODUCT DATA

Storage Sheets should be stored flat and face-to-face to reduce the possibility of damage. Bulk stocks should be stored flat on supports and covered to protect from dust. Sheets should be withdrawn in pairs with a sheet of paper between.

Handling To avoid scratching or marking the surface, work areas should be kept clean. Contact with any abrasive surface should be avoided. Sheets should be lifted carefully and care should be taken not to slide them on the decorative surface.

Cutting Formica® laminate should always be cut with the working face up to minimise surface chipping.

Hand Sawing A sharp panel saw gives good results due to its small teeth. The cutting stroke should be held at approximately 45° to the sheet and the back stroke should be light.

Machine Sawing Bench-type circular saws, with a pitch of 6mm to 8.5mm and only a slight set, provide a clean cut of the decorative surface.

Postforming Grade Laminate (HGP)

The postformable laminate that unleashes your design ideas away from the straight edge

Metal band saws are ideal for cutting shapes.

Planing An excellent edge finish can be achieved with a hand plane.

Hand Planing Specially hardened plane irons, such as "Titan", require less sharpening than standard iron plane knives.

Machine Planing Vertical spindle moulding machines with tungsten-tipped cutters are ideal for edge finishing and for making mitres.

Drilling Hand or power operated high-speed twist drills will cut clean holes. Due to the hard melamine surface, a small pilot hole should be drilled for carpenter's bits. Fast cut types give the best results. For large holes 20mm diameter and over, a centre bit should be used.

Bending Forming is accomplished by applying infra-red heat to the laminate in the area of the bend. Once it has reached the required temperature of 155°C-165°C, the sheet is formed with the aid of a mandrel. The sheet is allowed to cool and bond whilst held in the desired shape. Due to the high degree of control needed to bend Formica® laminate, this work is usually carried out in the workshop by an experienced fabricator using special postforming equipment.

Bonding Ensure that the surface to which the Formica® laminate is to be bonded is clean, dust-free and without irregularities. A more accurate job will result when bonding is done in the shop by a recognised fabricator, where proper equipment and conditions are available.

Formica® laminate can be bonded with several types of adhesive; the choice depends on the particular application. Refer to the adhesive manufacturer for details of particular adhesive types. All adhesive on the decorative surface should be removed immediately.

JOINING

Waterproof mastic should be used to prevent the ingress of water into the substrate or glue line at butt joints. Selleys Bath Tub Caulk-White or 781 clear silicone, or Dow-Corning 732 RTU clear silicone are recommended, used in accordance with the manufacturer's instructions. This should also be done when extruded aluminium or PVC joint strips are used.

Corner joining methods

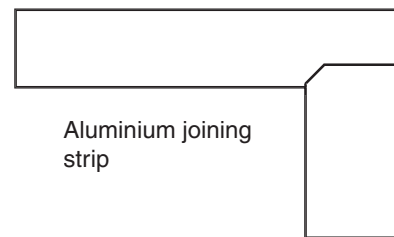
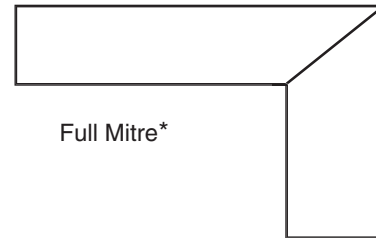

* Full mitre is the only means of joining a cove top or specially shaped components.

Each of these joining methods can be pre-cut by the fabricator for assembly on site.

The use of *Radiused* corners in cutouts is the recommended way of reducing stress by distributing it over a wider area rather than directing it to a 90° corner. It is important to smooth the edges of the radius cutout with a fine tooth file as this will further reduce any stress in the construction.

Over-cutting inside corners should be avoided as this may increase the risk of stress cracks.

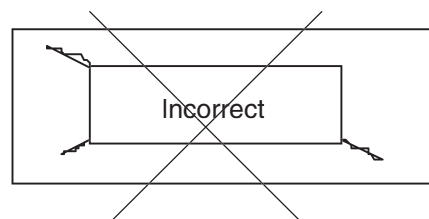

Square corners cut out

Postforming Grade Laminate (HGP)

The postformable laminate that unleashes your design ideas away from the straight edge

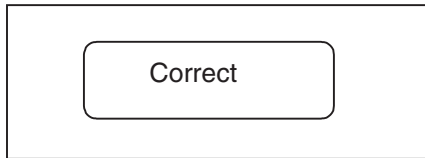

Radius corners cut out

SUPPLY

Please contact The Laminex Group Customer Services on 0800 303 606.

PACKAGING

Laminate may be supplied taped face-to-face or in crated packs according to quantity. Packaging of components is arranged between the fabricator and specifier.

CARE AND MAINTENANCE

Clean down regularly with NEW warm water and dishwashing detergent. Use "Ajax" Spray & Wipe to remove occasional stains. Stubborn stains should be removed by wetting the surface with a solution of 3 parts water to 1 part Janola; leave for 5 minutes then scrub with a nylon bristle brush.

DO NOT use abrasive cleaners on the laminate surface.

SERVICE

For additional sales and technical service regarding any Formica® surfacing material, contact The Laminex Group Customer Services:

Phone: 0800 303 606

Fax: 0800 303 707

HEALTH AND SAFETY

Inhalation of dust generated from processing Formica® decorative laminate may cause irritation and sensitisation by inhalation (asthma) and by skin contact (dermatitis). Repeated inhalation of dust may cause irreversible health effects including asthma, chronic nose or throat irritation or lung scarring. Do not breathe the dust. Wear a respirator when using power tools. For further information refer to the Formica® Laminate Material Safety Data Sheet.

Formica® is marketed, distributed and manufactured by The Laminex Group. A division of *FLETCHER BUILDING PRODUCTS LTD.*

Recommendations, suggestions or statements made in this brochure are intended to help customers. They are based on our experience and judgment. They should not be regarded as amounting to legal warranty or as involving any liability on our part.